

Whitby Mall

1615 Dundas Street East Whitby, ON L1N 2L1



About the Location

In the rapidly growing town of Whitby, just east of Toronto, is our vibrant shopping centre, Whitby Mall. Spanning over 394,000 sf, this centre features retail on the main level and offices above. This retail destination is grocery-anchored and is complimented by ample parking and a variety of amenities and services. Ideally situated adjacent to our Thickson Place centre, the synergy of these two centres provides convenient shopping for all neighbourhood residents.

Nearby amenities and tenants

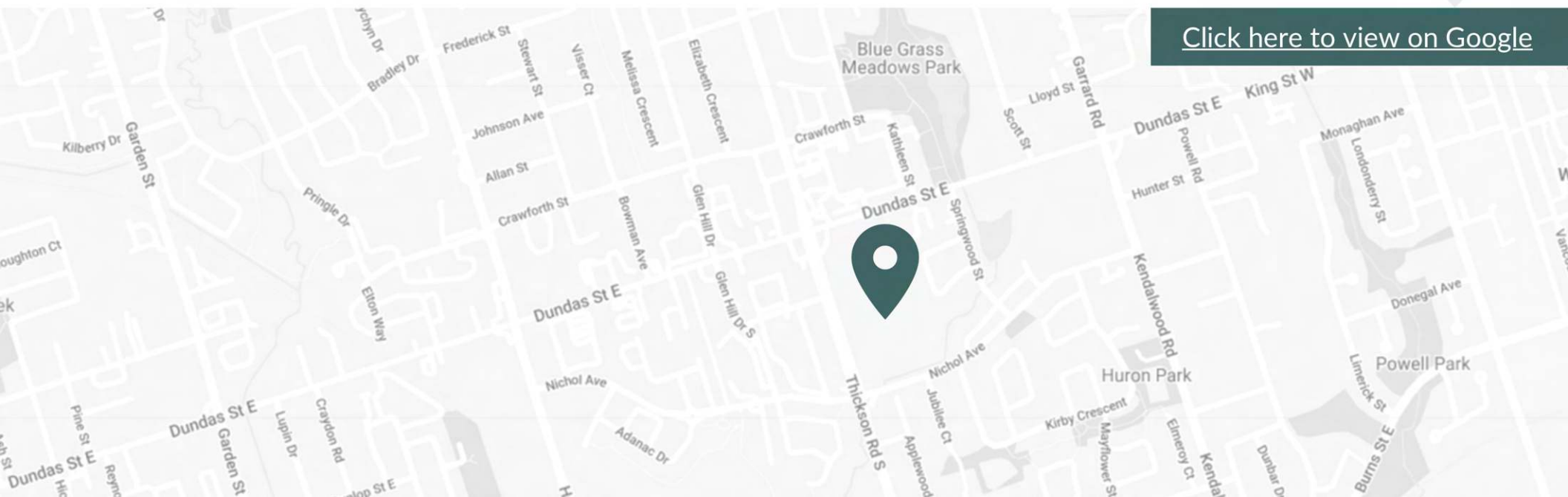

Whitby Mall

Whitby Mall features a 49,000 square foot Sobeys, Urban Planet, Graziella's Fine Jewellers, Talize as well as many other retailers below three levels of office space. It sits adjacent to First Capital's Thicksen Place, creating a synergy that provides a convenient shopping experience for the surrounding neighbourhood. It caters to a population of over 150,000 people within a five-kilometre radius, with an average household income of \$112,082.



Neighborhood Features



4-MINUTE DRIVE TO HWY 401



8-MINUTE DRIVE TO HWY 412



Population (5km)
150,552



Household Income (5km)
\$112,082



Households (5km)
56,268



Traffic count
37,200 (ADDT)



Nearest Bus line
905 route 905 at Thickson - On site



Nearest Rail line
Whitby GO Station - 4.5km





Dundas St

900

metro

Sobey's

Whitby Mall

BMO

Thickson Rd



905

Landmark
CENTRES
Where There's a Will, There's a Way

GoodLife
FITNESS

HWY 401



Dundas Street East

Entrance 1

Entrance 2

Thickson Road

Entrance 3

Entrance 4



56,268

Households



41,236

Families



40

Median age



8%

Increase in population by 2026

*5km radius

Leasing Opportunities

Unit Number	SF	Availability
A01007A	2,437	Immediately
A01027A	1,400	Immediately
A01048A	1,018	Immediately
A01050B	2,521	Immediately

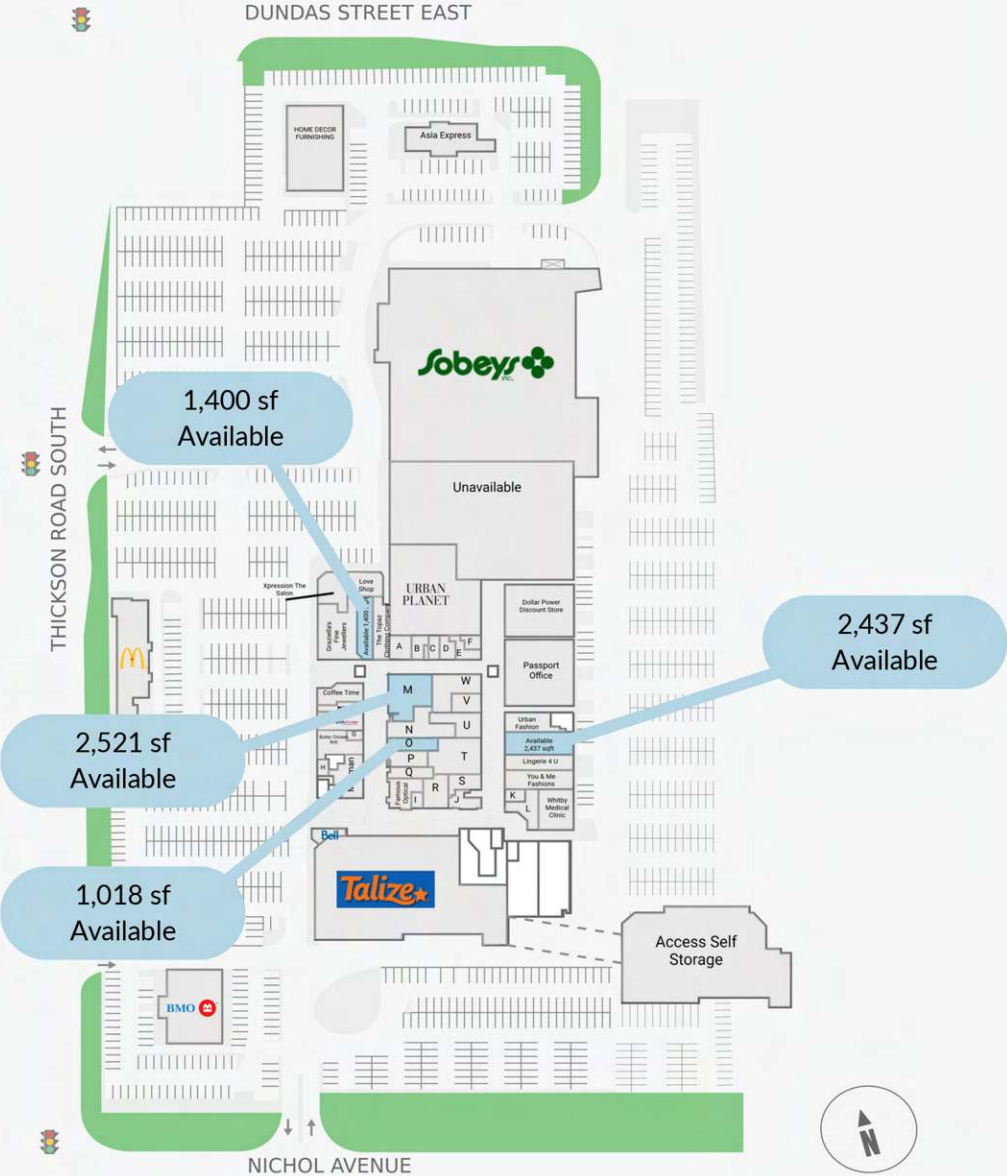

Unit - A01007A

Size	2,437 SF
Floor	1st
Available	Immediately
Ideal Use	Retail

**this is an approximate and rates are subject to change.*

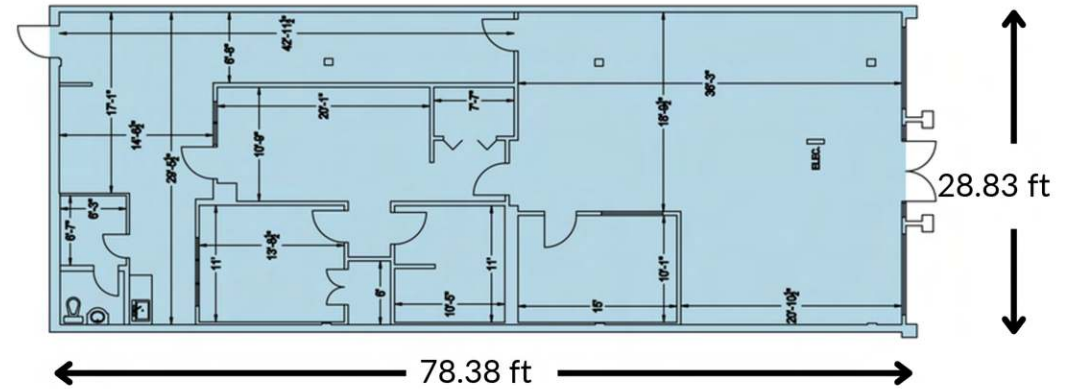

Unit - A01050B

Size	2,521 SF
Floor	1st
Available	Immediately
Ideal Use	Retail

**this is an approximate and rates are subject to change.*



Unit - A01027A

Size	1,400 SF
Floor	1st
Available	Immediately
Ideal Use	Retail

**this is an approximate and rates are subject to change.*

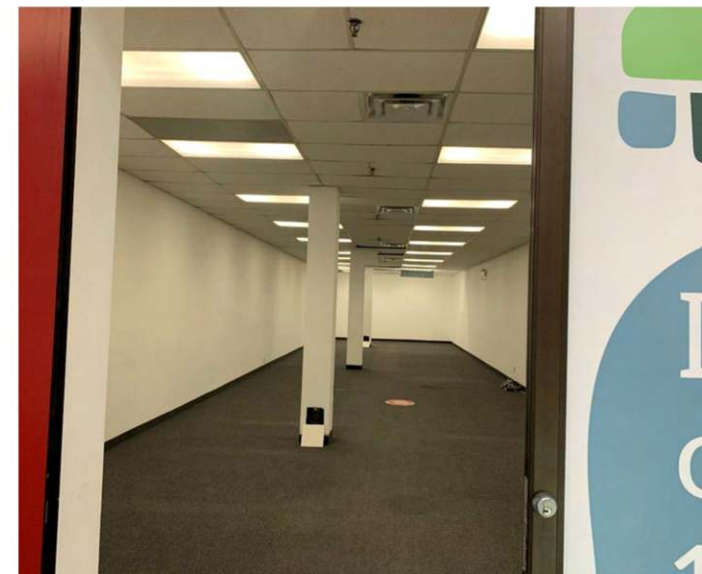
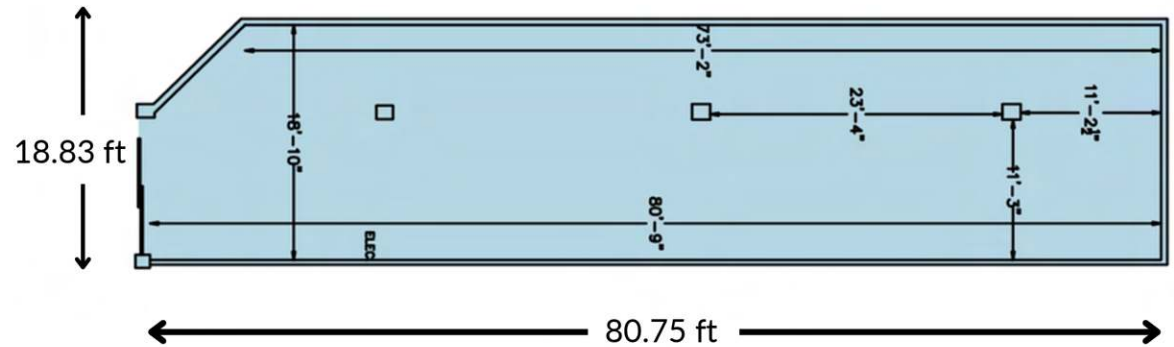

Unit - A01048A

Size	1,018 SF
Floor	1st
Available	Immediately
Ideal Use	Retail

**this is an approximate and rates are subject to change.*

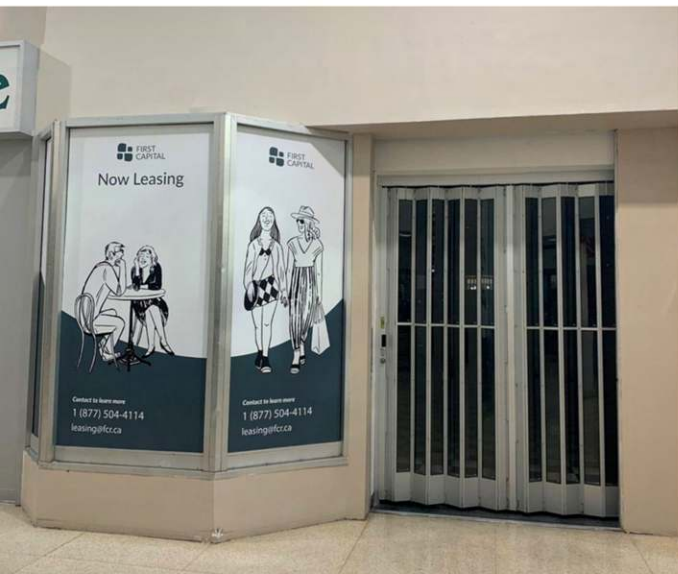
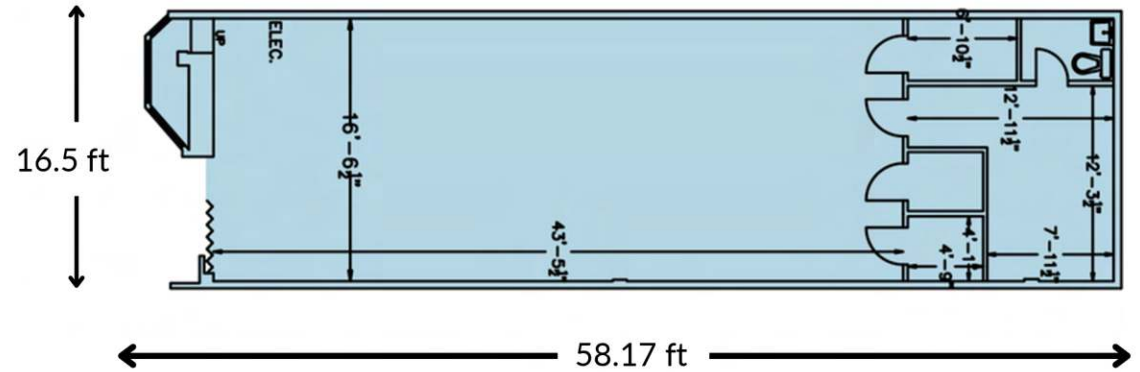



Matt Ashton
Director, Leasing
matt.ashton@fcr.ca
416.216.4203



Andrew Chiaino
Leasing Representative
Andrew.Chiaino@fcr.ca
647-501-7635