

# Fairmount Place

9919 Fairmount Drive South East, Calgary, AB



# Demographics & Neighbourhood

Located in the affluent community of Willow Park, Fairmount Place Shopping Centre is anchored by Calgary's largest Italian grocer, The Italian Centre Shop, as well as RBC and Tim Hortons. Drawing customers from across the city of Calgary, this centre is ideally situated in a densely populated and diverse neighbourhood providing for everyday needs and more. Fairmount Place Shopping Centre is surrounded by several parks and schools, is seconds away from the busy intersection of Macleod Trail SE and Southland Dr SE, and under 10 minutes to DeerFoot Trail.

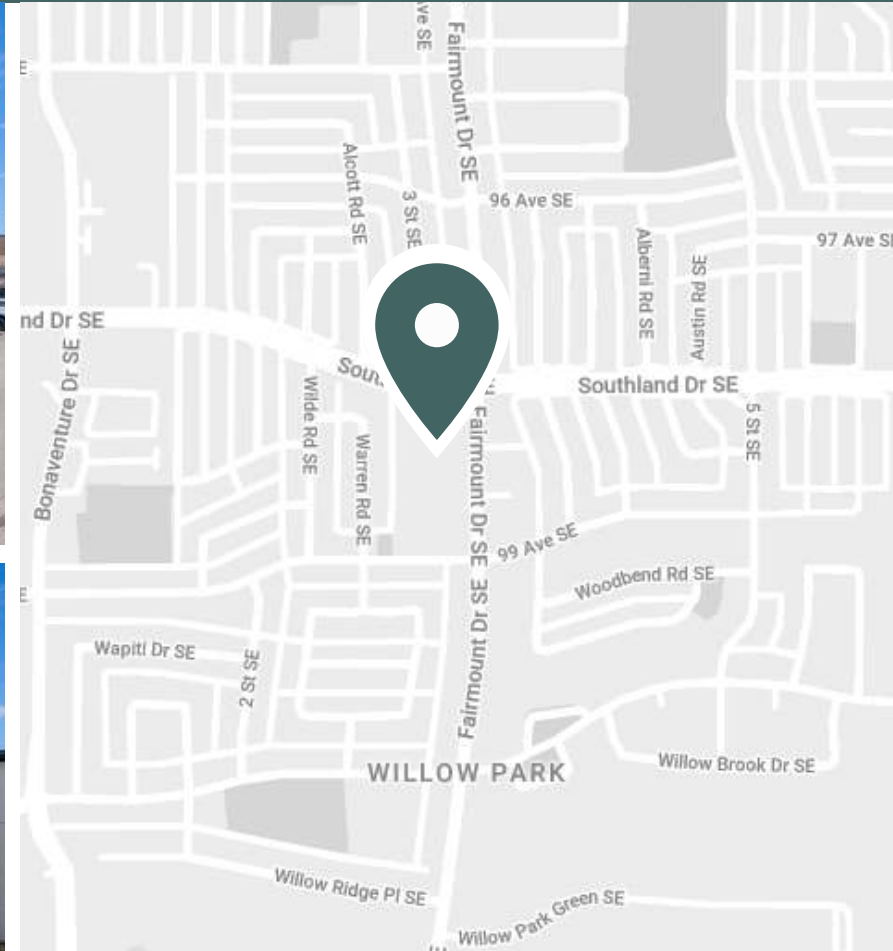

# Neighbourhood Features



3-MINUTE DRIVE TO THE WILLOW  
PARK GOLF & COUNTRY CLUB



4-MINUTE DRIVE TO  
SOUTHCENTRE MALL



7-MINUTE DRIVE TO SUE  
HIGGINS PARK



Population (5km)  
142,454



Bike Score  
73



Household Income (5km)  
\$136,321



Traffic count  
26,000



Households (5km)  
57,565



Nearest Bus line  
10 City Hall/Southcentre - 0.1km



Nearest Rail line  
Southland CTrain Station - 1.2km



# Leasing Opportunities

Unit	Unit Number	SF	Ideal Uses	Availability
A	A02206B	1,142	Office	Immediate
B	A02207A	1,047	Office	Immediate
C	A02201A	1,084	Office	Immediate
D	A02202A	1,154	Office	Immediate
E	ABM149A	1,742	Office/Retail	Immediate
A & B	A02206B A02207A	2,189	Office	Immediate

Fairmount Place Shopping Centre currently offers six office spaces ranging in size from 1,047 sf to 2,189 sf. Our prime location offers easy access to major highways and is minutes from public transportation, making it convenient for both employees and clients. Customize your space to fit your unique business needs.

## Main Floor & Basement:\*

CAM: \$6.54

Tax: \$9.87

\*2024 estimates

## Second Floor:\*

CAM: \$14.30

Tax: \$9.77



# Availabilities

<b>Size</b>	1,142 SF
<b>Floor</b>	2
<b>Unit Number</b>	A02206B
<b>Additional Rent (psf)*</b>	\$24.07
<b>Available</b>	Immediate
<b>Additional Information</b>	Office

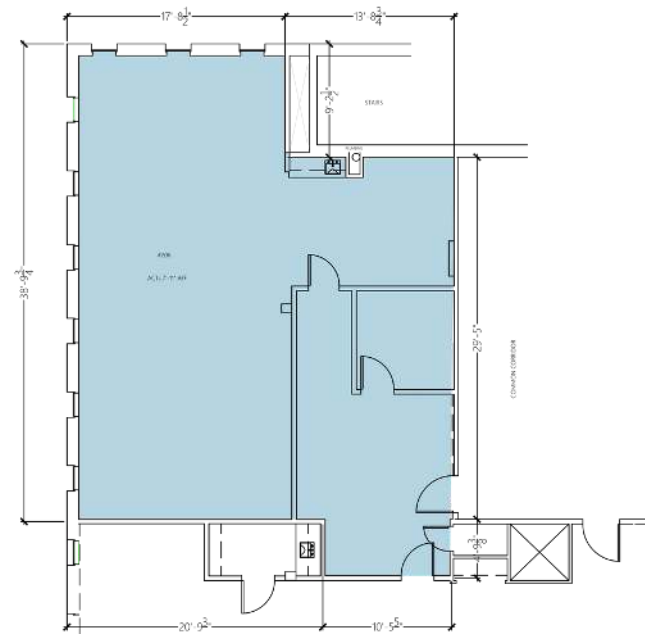

<b>Size</b>	1,047 SF
<b>Floor</b>	2
<b>Unit Number</b>	A02207A
<b>Additional Rent (psf)*</b>	\$24.07
<b>Available</b>	Immediate
<b>Additional Information</b>	Office

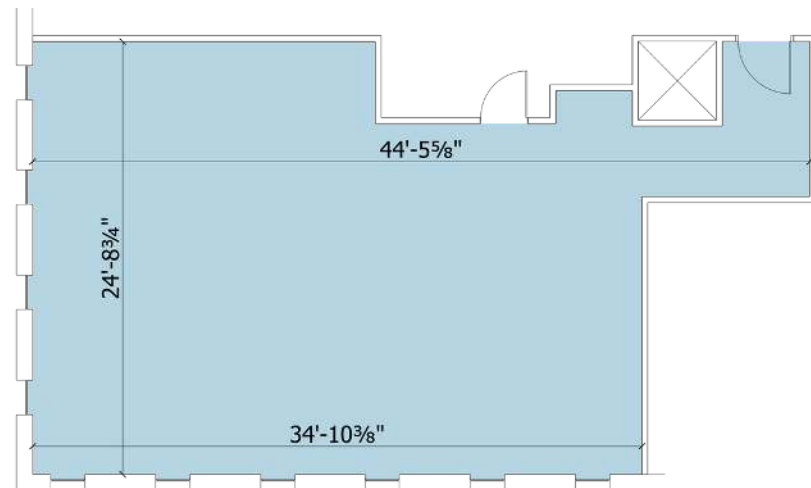

# Availabilities

Size	1,084 SF
Floor	2
Unit Number	A02201A
Additional Rent (psf)*	\$24.07
Available	Immediate
Additional Information	Office

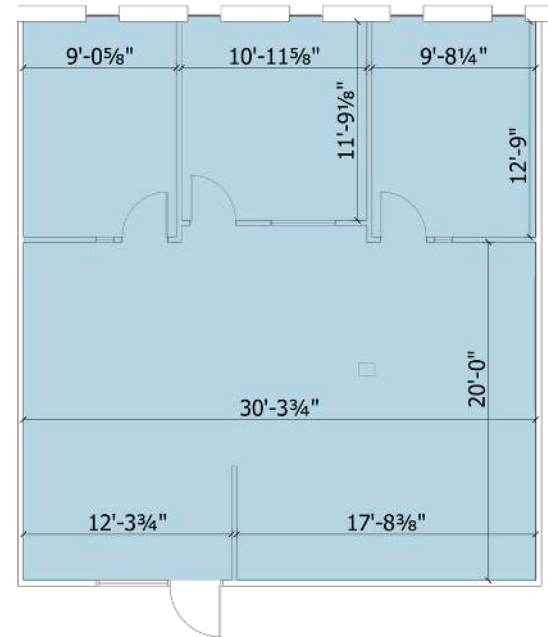

Size	1,154 SF
Floor	2
Unit Number	A02202A
Additional Rent (psf)*	\$24.07
Available	Immediate
Additional Information	Office

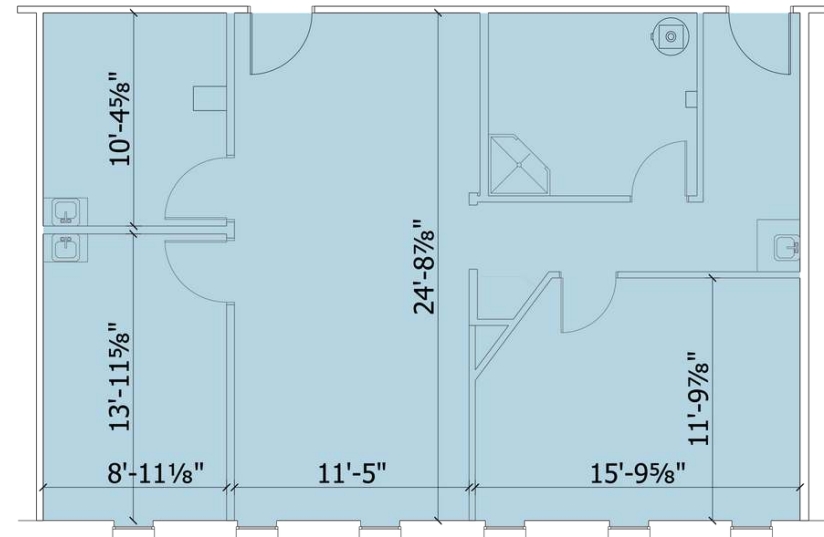

# Availabilities

<b>Size</b>	1,742 SF
<b>Floor</b>	basement
<b>Unit Number</b>	ABM149A
<b>Additional Rent (psf)*</b>	\$16.41
<b>Available</b>	Immediate
<b>Additional Information</b>	Office/ Retail

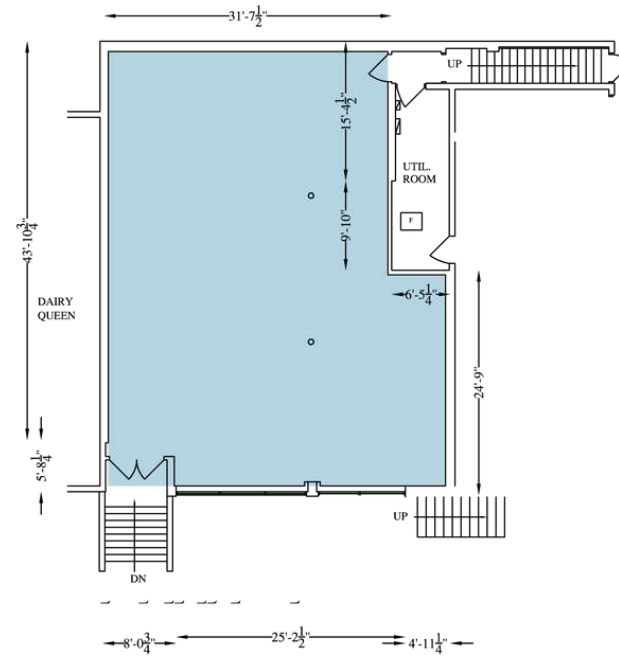



**Brent Watson**  
Leasing Representative  
[brent.watson@fcr.ca](mailto:brent.watson@fcr.ca)  
[403.612.1654](tel:403.612.1654)